



**QUATECH**

CONNECT WITH RELIABILITY

# Application Note

## Transition to DP550 Devices

Revision: 1.0

April 2011

File name: transition to dp550 application note

Document Number: 100-8091-100

## 1.0 Overview

Moving from one product generation to a new one can be a daunting task, as incompatibilities with hardware and software have the potential for introducing significant development and support issues for both you and your customer. Quatech believes the transition should be as smooth as possible, with minimum interruption and effort on your behalf. Our engineers strive to maintain both hardware and software backward compatibility creating an ever evolving superset of functionality as the product develops and new features are added.

Unfortunately, device obsolescence is inevitable due to the dynamics of the digital electronics world. Quatech aims to isolate our customers from these changes as much as possible by making our hardware interfaces and software API's device independent. While we have been successful for the most part, even with our best efforts we sometimes are required to issue an end-of-life notification on a product or product family; in these cases, Quatech always ensures that there is a valid alternative. The following document has been issued to deal with such a transition.

Due to a major component going end-of-life, the Airborne DP100 and DP500 embedded product families will be withdrawn from our catalogue in coming months. However, Quatech recently introduced the DP550 family of devices to provide a seamless migration for our existing customers. To aid in the transition, Quatech has provided the following information so that you can be fully informed of the appropriate product to which to migrate and understand the implications of the move.

## 2.0 Product Comparison

Whenever a product transitions there will be differences between the original product and the one you transition to. The following table outlines the major feature differences between the DP100, DP500 and DP550 embedded modules (changes also apply to the corresponding Airborne PCB assembly products that start with the ABDG prefix).

Feature	WLNG-XX-DP101	WLNG-XX-DP501	WLNG-XX-DP551
<b>Radio Technology</b>	Marvel 8385 ( <i>5 years old</i> )	Marvel 8385 ( <i>5 years old</i> )	Atheros AR6002 ( <i>&lt;2 years old</i> )
<b>CPU Technology</b>	8-bit Uvicom	32bit ARM9	32 Bit ARM9
<b>Memory</b>	160Kb SRAM/512Kb Flash	128Mb SDRAM/64Mb Flash	128Mb SDRAM/64Mb Flash
<b>Operating Temperature Range</b>	-40°C to +85°C	-40°C to +85°C	-40°C to +85°C
<b>RF Performance</b>	Good	Good	Best-in-class <i>Rx Sensitivity improved by as much as 6dB (Double the range)</i> <i>802.11g Tx power up by 2 dBm</i>
<b>Operating Power</b>	Good	Better	Operating power 50% less
<b>Size</b>	40.6mm x 29.60mm x 12.37mm	40.6mm x 29.60mm x 12.37mm	40.6mm x 29.60mm x 7.47mm
<b>Boot time</b>	6 seconds	11 seconds	7 seconds
<b>Throughput Performance</b>	Single 460K UART 1Mb/s SPI 4-6Mb/s Ethernet	Dual 921K UART 4-6Mb/s SPI 8-9Mb/s Ethernet	Dual 921K UART 4-6Mb/s SPI 16-19Mb/s Ethernet
<b>Antenna Diversity</b>	Rx only	Rx only	Tx and Rx
<b>Security Support</b>	WEP/WPA-PSK/LEAP	WEP/LEAP WPA-PSK/WPA2-PSK WPA/WPA2-Enterprise EAP-TLS/TTLS/PEAPv0/FAST	WEP/LEAP WPA-PSK/WPA2-PSK WPA/WPA2-Enterprise EAP-TLS/TTLS/PEAPv0/FAST
<b>Certificate Support</b>	None	Storage for multiple certificates & private keys	Storage for multiple certificates & private keys
<b>Configuration Management</b>	Customer FW Builds	User and OEM File	User and OEM File
<b>Airborne Management Center Support</b>	Discovery, management & configuration	Enhanced Discovery, management, firmware update, configuration control	Enhanced Discovery, management, firmware update, configuration control
<b>Regulatory Certification</b>	FCC Modular Approval ETSI EN 300-328	FCC Modular Approval ETSI EN 300-328	FCC Modular Approval ETSI EN 300-328

### 3.0 Equivalent Parts

In any transition, it is important to know what the correct equivalent part to migrate to is. This not only minimizes any disruption, it also helps focus any issues to those related directly to the specific application. The following table provides a guide on the equivalent part numbers. If you do not see your part number on the list please contact Quatech Sales and they will correctly identify the equivalent device.

New Part No.	Equivalent Parts	
<b>Airborne™ Modules</b>		
WLNQ-AN-DP551	WLNQ-AN-DP101	WLNQ-AN-DP501
WLNQ-BR-DP551	WLNQ-ET-DP101	
WLNQ-ET-DP551		WLNQ-ET-DP501
WLNQ-SE-DP551	WLNQ-SE-DP101	WLNQ-SE-DP501
WLNQ-SP-DP551	WLNQ-AN-DP102	WLNQ-SP-DP501
<b>AirborneDirect™ Wireless Device Server and Ethernet Adapters</b>		
ABDG-BR-DP501	ABDG-ET-DP101	
ABDG-BR-DP553	ABDG-ET-DP103	
ABDG-BR-DP554	ABDG-ET-DP104	
ABDG-ET-DP553	ABDG-ET-DP503	
ABDG-SE-DP551	ABDG-SE-DP501	ABDG-SE-DP101
ABDG-SE-DP553	ABDG-SE-DP503	ABDG-SE-DP103
ABDG-SE-DP554	ABDG-SE-DP504	ABDG-SE-DP104
ABDG-SE-DP556	ABDG-SE-DP506	ABDG-SE-DP106
ABDG-SE-DP557	ABDG-SE-DP507	ABDG-SE-DP107
<b>Evaluation Kits</b>		
WLNQ-EK-DP551	WLNQ-EK-DP001 WLNQ-EK-DP003 ABDG-ET-DP104	WLNQ-EK-DP501 WLNQ-EK-DP502 WLNQ-EK-DP503

## 4.0 Transition Considerations

The DP550 product family was designed to be form, fit and functionally compatible with both the DP100 and DP500 families. The following sections provide guidance on those areas that may be impacted when moving from the DP100 and DP500 families to the DP550 products. It is important these are reviewed and understood, as they can impact your hardware, software, product certification and documentation. If the impact of any of the following items is not clear, please contact Quatech directly.

### 4.1 Regulatory Certification

The DP550 product family utilizes the latest 802.11 technology from Atheros. The use of a new radio required Quatech to complete new modular certification for the product family; this has resulted in new FCC and Industrie Canada (IC) grants. The new grant numbers are shown in the table below.

Country	Standard	Grant
North America (US)	FCC Part 15 Sec. 15.107, 15.109, 15.207, 15.209, 15.247 Modular Approval	F4AWLNG551
Canada	RSS 210 Modular Approval	3913A-WLNG551

Under the FCC and IC guidelines, it is necessary for all products utilizing the DP550 devices to replace the old grant numbers with the new ones. A full description of the requirements can be found in section 12.0 of the DP550 Platform Product Specification.

There is no requirement to change your existing antenna when making the transition. Quatech has maintained the approved antenna list it supported with the DP100 and DP500 families.

If you require copies of the new grants, test reports or antenna list please contact Quatech sales.

### 4.2 Mechanical Size

The DP550 module family has achieved a much higher level of hardware integration than either the DP100 or DP500 products. The result is a much lower profile for the module. The new mechanical dimensions can be found in section 10.0 of the DP550 Platform Product Specification.

### 4.3 Mounting Hardware

The DP550 is plug-in compatible with both the DP100 and DP500 devices. Quatech has introduced with the DP550 a revolutionary friction fit mounting system to ease assembly and maintenance of products that use the module. The new mounting hardware requires the module to be mounted from the top of the system's board by pushing down on the corners of the device. Additional mounting screws are no longer required.

Quatech has tested the mounting system for both shock and vibration compliance and can supply test reports upon request.

For applications that have additional mounting requirements, Quatech does support heavy duty mounting hardware. If you believe your application requires this, please contact Quatech sales.

Note that mounting of Airborne embedded PCB assemblies will not change with the new DP550 introduction. These systems can maintain their original mounting designs.

#### 4.4 Support for 10/100 Ethernet Interface

One of the significant hardware updates in the DP550 product family is the availability of a 100Mb/s Ethernet interface. The new Ethernet interface supports 10Mb/s and 100Mb/s, as well as half and full duplex and auto-negotiation of rate.

If transitioning from the DP500 family, there is no additional work to be done.

If transitioning from the DP100 family, the updates to the Ethernet interface may require modification to your existing design. This is particularly true if you have employed a capacitive coupling network between the DP100 and your system's Ethernet PHY.

Quatech recommends you initially try the DP550 in your design to establish if additional work is required.

The following network is the recommend configuration for DP550 Ethernet capacitive coupling; however, due to the variations in Ethernet PHY design, it is recommend that you contact the manufacturer of the PHY being used for application guidance.

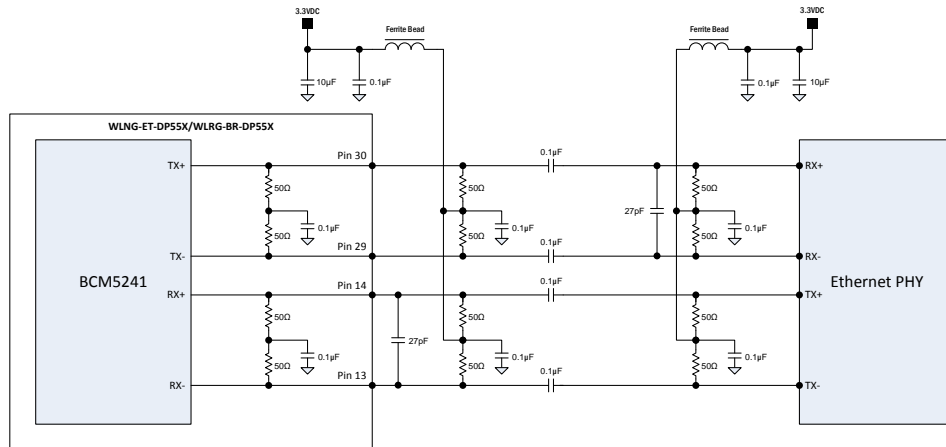

Historically, using auto-negotiate, with a capacitive coupling network has been difficult. Quatech recommends that auto-negotiate not be used when implemented with the DP550 devices. The Ethernet mode can be set via the web interface via the **Configuration| Ethernet Settings| Ethernet Port Speed/Duplex** field or through the CLI interface using the **eth-mode** command.

#### 4.5 SPI Interface

The DP550 family has an improved SPI protocol designed to provide a significant increase in throughput on the API interface. The hardware interface is compatible with all families, although signal timing must be reviewed when moving from the DP100 family to the DP550.

The new SPI protocol is fully described in section 7.0 of the DP550 Platform Product Specification.

Quatech recommends using the Cheetah SPI Host Adapter development tool from Total Phase, Inc. when developing with the DP550 SPI interface.

#### **4.6 Access to Web Interface**

The DP550 product supports an embedded web server through which device configuration, status and firmware updates can be accessed. If transitioning from the DP100, this will be a new interface. Access to the web interface is via the WLAN IP address on port 80, and if using the module as a router on the gateway IP address port 80.

You will be required to authenticate; please enter the username and password you use for CLI access.

#### **4.7 New Firmware**

The DP550 family has its own firmware; it is not possible to use either the DP100 or DP500 firmware on the device. You can download the latest version of firmware from the Quatech support site at [www.quatech.com/support/driver.php](http://www.quatech.com/support/driver.php). Be sure to look for the correct product name and follow the links.

## 5.0 Change Log

The following table indicates all changes made to this document:

Version	Date	Section	Change Description	Author
1.0	4/19/2011	-	Initial release	ACR